

Heliport Perimeter Light is used for night operation, to use omnidirectional green perimeter light lighten the heliport TLOF/FATO edge area. TLOF lighting system always consist of elevated/flush perimeter lights and floodlighting by ICAO standards.

Applications:

- Raised mounted marking edge of FATO area or TLOF area
- Taxiway edge lights-blue
- Landing direction lights

Compliant:

- ICAO Annex 14, Volume II, 4th Edition, July, 2013
- FAA AC150/5390-2C
- Exceeds FAA Engineering Brief 87 Specifications

Why HL-51:

- Portable and lightweight, easy transportation and installations.
- Low profile, no more than 25cm in height required by ICAO.
- Base plate is easily removable for a flexible installation.
- Ingress protection rating IP65.
- Built in surge protection device bear harsh outdoor conditions.
- Fresnel lens makes beams more concentrated.

Physical Characteristics:

- Die-casting aluminum body and base.
- Aviation yellow powder coating finish.
- Impact resistant polycarbonate lens cover.
- Sealed by rubber O ring.
- Diameter 5.3"/13.5cm, 9.25"/23.5cm in height.
- IP65
- 1.5KG weight.

Electrical Characteristics:

- Power by 220V AC, or 48V DC option.
- 5 W low power consumption.
- Green color LED light source 50,000 hours lifetime.

Environmental:

- Operating at -40°C to 60 °C.
- Wind speed: 80m/s.

Mounting Size:

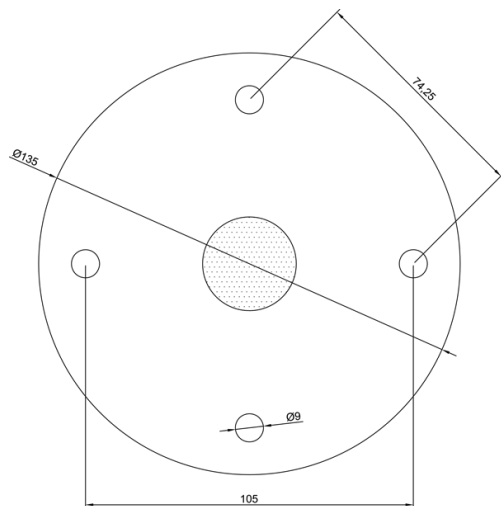

Optical Characteristics:

Elevation angle	Azimuth	Light Intensity
20° to 90°	-180° to 180°	>3cd
13° to 20°	-180° to 180°	>8cd
10° to 13°	-180° to 180°	>15cd
5° to 10°	-180° to 180°	>30cd
2° to 5°	-180° to 180°	>15cd

Ordering codes:

Type	Output	Lamp	Base plate
HL-51	G: Green B: Blue R: Red W: White Y: Yellow	AC: 220V DC: 48V	Default included in package

Project:

